

2021

EURO-RELAIS

Equipment for your Service Area

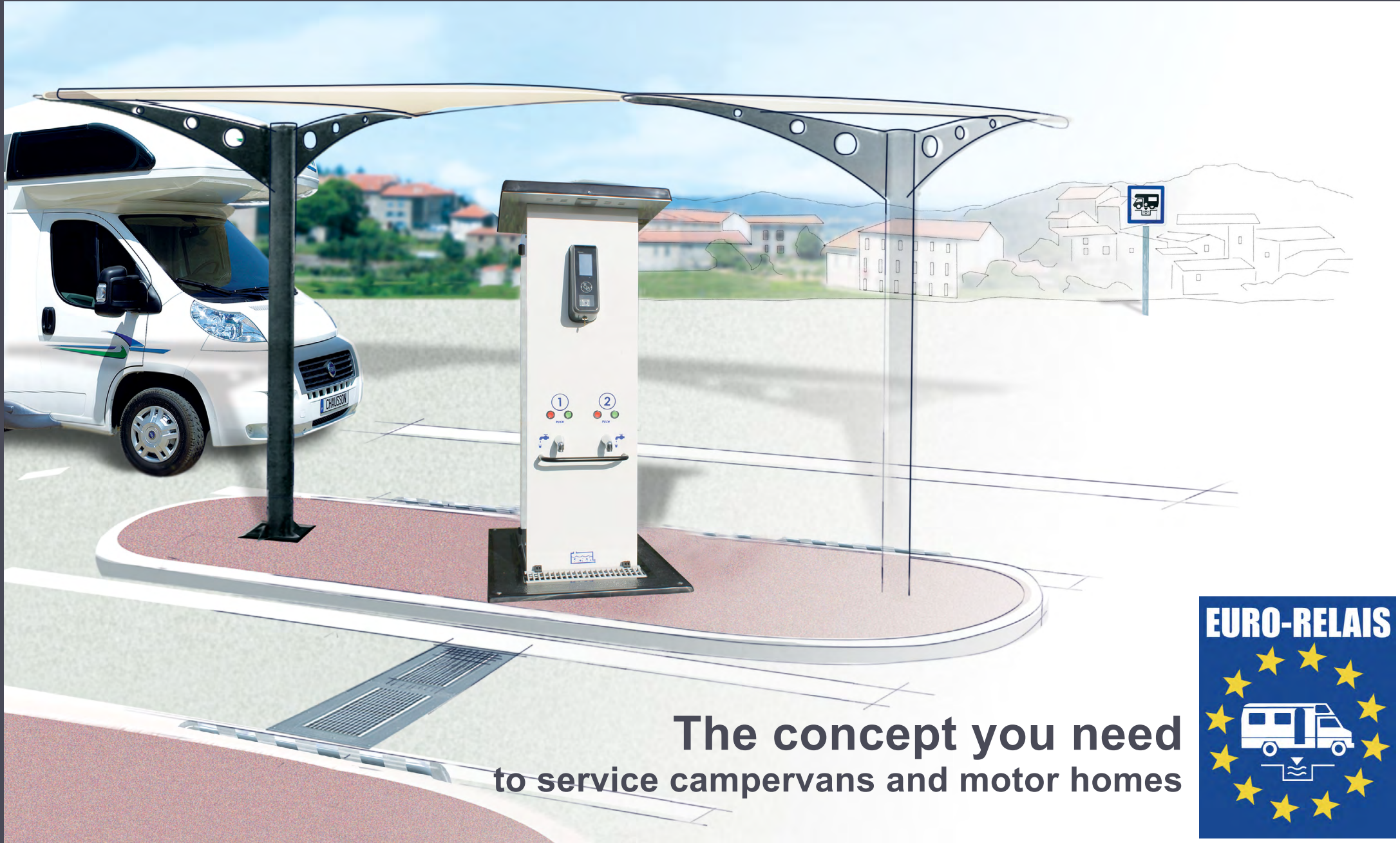

**The concept you need
to service campervans and motor homes**





The Euro-Relais concept

THE N°1
NETWORK
IN EUROPE

Campervan drivers will love you for it

Campervans in France:
505,000 campervans on the road, with 1.4 million enthusiasts

Campervans in Europe:
2,000,000 campervans on the road, with 5 million enthusiasts

It's up to us to offer them the best possible conditions and help protect the environment by reducing campsite pollution.

SERVICE AREA

STOP-OVER AREA

Your regional communities will love you for it

The majority (62%) of campervan users spend between 15 and 50 nights in their campervans (for all destinations), with an estimated average of 41 days per year.

An experienced couple of campervan enthusiasts will need around 150 litres of clean water every 3 days.

Nature will love you for it

Each time a campervan enthusiast passes through and uses a Euro-Relais service area, it helps protect the environment.

CONTENTS

Maxi point (Credit card payment)	04
Maxi point (Token payment).....	06
Mini point (No payment)	08
Multi-service point equipment	09
Euro Park Electrical point	10
Service Area accessories.....	11
Installation, technical data sheet, contract	12
Contact and information	15



EDITORIAL

So why should you set up a Service and Stopover Area in your commune?

We provide the best possible conditions for campervans throughout the year, providing service and stopover areas designed to fit into your commune beautifully, while remaining a key strategic asset for you.

The most obvious advantage is the economic one: when campervans stop, their users take the opportunity to go shopping, visit a monument, dine at restaurants and much more – in your commune.

From an environmental point of view, a service area is the ideal place for campervan users to dispose of their grey and wastewater easily and legally. They can take advantage of these services in calm, green locations which provide easy access to your local shops and town centres.

An essential solution for users across Europe, a whole host of new installation systems have been designed and developed to ensure that Euro-Relais areas are perfectly adapted to your commune, while also working in synergy with local campsites, superstores, service stations and motorway services.

Modernise your services with card payment solutions, and make it easier for users to spend more time and money in your service area!

In short, Euro-Relais provides a truly global, innovative solution for your projects! We offer key benefits for your local development: exceptional services, in which hygiene and cleanliness are your top assets.

When you choose Euro-Relais, you're choosing the largest network in Europe. You'll join 2200 existing locations, and take advantage of more than a quarter-century of expertise.

With Euro-Relais, we'll go further together.

Sales Director
Anthony PEGAIN

What's the difference between a Service Area and a Stopover Area?

A SERVICE AREA is a sanitary station fitted with a multi-function service point, which allows campervans to empty their grey water (kitchen and basins) and their wastewater (toilets), and also to refill their clean water. Additionally, they provide short-term battery recharging facilities – a service area is not designed for long stays. Service areas should ideally be near city and town centres, giving them good access to the various utilities running to the utility points. Euro-Relais Service Areas play a major role in developing local tourism.

A STOPOVER AREA, on the other hand, allows campervans to stop over on their way to another destination (generally 24 or 48 hours). These spaces are specially designed to house campervans and motorhomes, and are located in calm, green areas near shops and city centres. A Euro-Relais Stopover Area gives campervan users access to additional services to enhance their visit. It can also help direct campervan users towards local businesses, culture and sporting activities in your district.

New contactless card (or mobile) payment points



French innovation for campervans
and local development









EURO-RELAIS







www.bornes-eurorelais.com

The European Service Area Network



-  Contactless card payment
-  Mobile phone payment
-  Wi-Fi connection
-  Remote troubleshooting
-  All-year use
-  Visitor statistics
- Toilet emptying
- Wastewater emptying
- Drinking water tap
- Rinse water tap



-  Contactless card payment
-  Mobile phone payment
-  Wi-Fi connection
-  Remote troubleshooting
-  All-year use
-  Visitor statistics



MAXI point: 2 vehicles

Credit card payment

M/ERLX2CB	8945 €HT
-----------	----------

Base (required)

M/ERLX2CB	111 €HT
-----------	---------

EURO-PARK electric point: 4 vehicles

Credit card payment

M/ERPX4CB	6796 €HT
-----------	----------

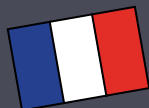

Working hard for camping car users and local areas

The rise of smartphones has revolutionised the tourism sector, bringing new innovations and changing travellers' habits. Professionals and local authorities have had to provide new, flexible tools in order to provide every type of service quickly and easily, while making them simple and secure to pay for.

To keep up with the changing industry, TRIGANO has developed the next-generation **Maxi and Euro-Park** points alongside the EASYTRANSAC start-up and the FAMOCO Company – the leader in secure professional Android terminals.

These points are fitted with a fully modular system, designed to adapt to new payment methods and providing the security and availability needed for both users and local authorities.

Thanks to the EASYTRANSAC solution, users can pay to fill up with drinking water with their contactless card, or through an optical card scanning system.



FRENCH INNOVATION FOR THE GLOBAL MARKET

This next-generation terminal is a fully modular technological solution, making it cheaper and easier to install than any systems currently available on the market. Thanks to the integrated EASYTRANSAC operating system, it is totally secure and can receive new updates and applications in real time via a remote management platform. This allows the system to adapt to new offers and uses quickly and effectively.

With this new system, operators can make major savings on their operating costs – in particular concerning installation and maintenance, while also enhancing the user experience. The validation system is available in several different versions, ensuring it can adapt to the specific features and constraints of every market.

A FRENCH PARTNERSHIP



Borne paiement jeton - EURO-RELAIS



French innovation for campervans
and local development



EURO-RELAIS

www.bornes-eurorelais.com

The European Service Area Network



Toilet emptying
Wastewater emptying
Drinking water tap
Rinse water tap



MAXI point: 1 vehicle

Token payment

M/ERLX1JES	4720 €HT
------------	----------

Token payment

M/ERCE1	111 €HT
---------	---------

Pack of 100 EURO RELAIS tokens

ERMSJE	74 €HT
--------	--------

The EURO-RELAIS Multi-Service MAXI Point



The Maxi Point is specially designed to meet the latest needs and demands from local authorities and campervan users, whatever the season. They are supremely hard-wearing, resistant to impacts and vandalism.



Elle résiste à tous les chocs ainsi qu'aux actes de malveillance.



Characteristics of the Euro-Relais 2021 MAXI Point		
	Maxi Point: 1 Vehicles	Maxi Point: 2 Vehicles
Payment	Euro-Relais token payment	Contactless card and mobile payment
Drinking water taps	1	2
Rinsing taps	1	1
Wi-Fi	No	optional
Plexiglas showcase	optional	Yes
Snow kit	optional	Yes
Flow controller	No	Yes
Anti-freeze kit	Heating band and thermostat	Heating band and thermostat + wall insulation
WC drain	Yes	
Materials	Base and cap: polyester, Column: 304-grade stainless steel, painted white	
Command type	Push button on/off, automatic system	
Lighting	3 spotlights: LED SMD 0.8W 3000K 55lm	
Closing	3-point locked door	
base (obligatory)	To be interred and pre-connected with shared grey and wastewater drainage pipes	



Maxi point: 1 vehicle

M/ERLX1JES 4720 €HT

Maxi point: 2 vehicles

M/ERLX2CB 8945 €HT

Base (required)

M/ERCE1 111 €HT

Euro Drain (300 x 30 cm)

M/ERACO3 1016 €HT

Allows you to empty grey water, with integrated rinse.

EURO-RELAIS Multi-Service MINI Point – No payment system



Mini Point for 1 VEHICLE

Discreet and elegant, the Mini Point is perfect for seasonal use (e.g. outdoor hotel services).



Characteristics of the Euro-Relais 2021 MINI Point	
Mini Point: 1 Vehicle	
Payment	None
Lighting	None
Drinking water taps	1
Rinsing taps	1
Toilet drainage	Yes
Grey water drainage	Yes
Anti-freeze kit	Yes
Wi-Fi	No
Material	Base and cap: polyester, Column: 304-grade stainless steel, painted white
Control type	Push button PRESTO timer system
Locking	2-point locked door
Base (included)	To be interred and pre-connected with shared grey and wastewater drainage pipes



Mini point: 1 vehicle

M/ERMX1 2488 €HT

Base (required)

M/ERCE1 111 €HT

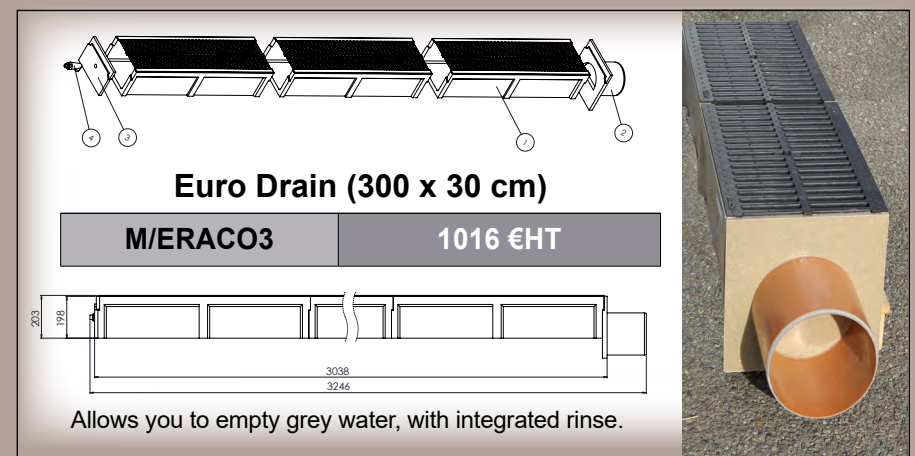
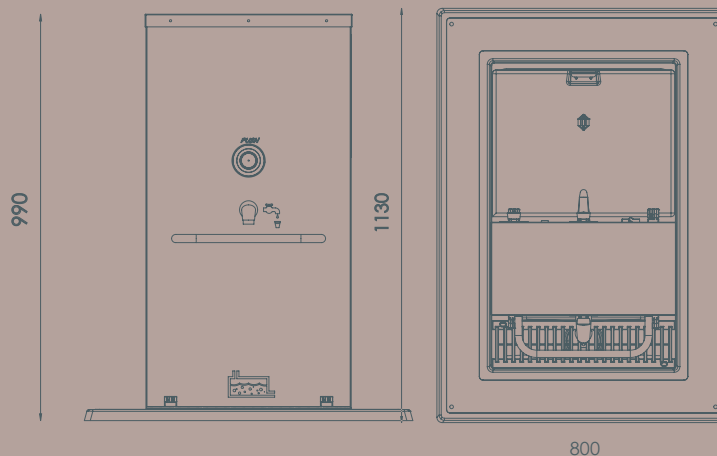

EURO-RELAIS Multi-Service Point Equipment



Drinking water taps for 1 or 2 vehicles



Solenoid valve-controlled rinsing tap



Wastewater drainage



Toilet drainage with integrated rinse



Automatic lighting for Maxi point: 1 or 2 vehicles



SNOW KIT: protects the point from temperatures below -20°C

for Maxi point: 1 or 2 vehicles



Key-lock service doors



Snow kit + walls insulated by padded aluminium film

included : Maxi 2V
Optional : Maxi 1V

ERJHG

105 €HT



WINDOW: integrated Display: A3 Plexichocs® 4mm 2 key security

included : Maxi 2V
Optional : Maxi 1V

M/VIT001

174 €HT



Scanner and payment

- Contactless card payment
- Mobile phone payment
- Wi-Fi connection (optional)
- Remote troubleshooting
- Visitor statistics

For MAXI Point (2 vehicles)



Token machine

Euro-Relais tokens

Can be used with points featuring these machines.

For MAXI Point (1 vehicle)

EURODRAIN

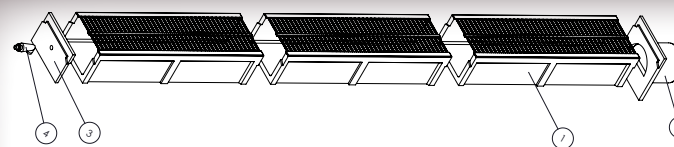

Euro Drain (300 x 30 cm)

M/ERACO3

1016 €HT



Allows you to empty grey water, with integrated rinse.



EURO-RELAIS Electrical Point: 4 vehicles



Characteristics of the Euro-Relais 2021 electrical point	
Material	Base: polyester, Column: 304-grade stainless steel, painted white
Control type	automatic
Lighting	3 spotlights: LED SMD 0.8W 3000K 55lm
Locking	2-point locked door
Base	TO BE INTERRED AND PRE-CONNECTED WITH ELECTRICAL GRID
Payment	Contactless and mobile
P17 sockets	4
Wi-Fi (optional)	Yes

4 VEHICLE ELECTRICAL POINT

This point provides power to 4 single-phase sockets to charge campervan batteries. It is used in much the same way as a car park payment system.

The client uses their credit card to pay on the Famoco module, paying for 3-6-12-24 hours' power.

Euro-Park 4V	M/ERPX4CB	6796 €HT
---------------------	------------------	-----------------

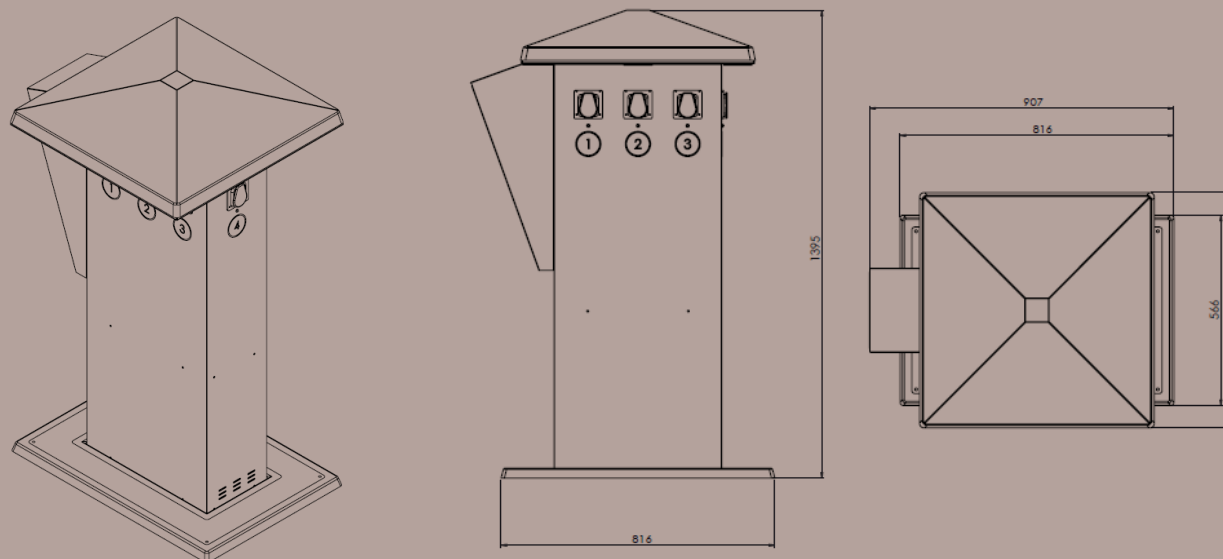

Service Area Accessories



CE24 PANEL + MAST

Approved for road sign use, format 50x50cm, 3m mast. Essential to signpost your service area.

980223	188 €HT
---------------	----------------



GUIDE BARRIERS

Create an access route to the utility point or floor drain.

ERP2	41 €HT
-------------	---------------



CORNER BARRIER

Protect your service area accessories from any bumps.

ERP1	35 €HT
-------------	---------------

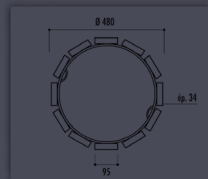
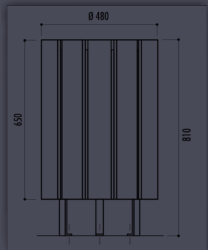
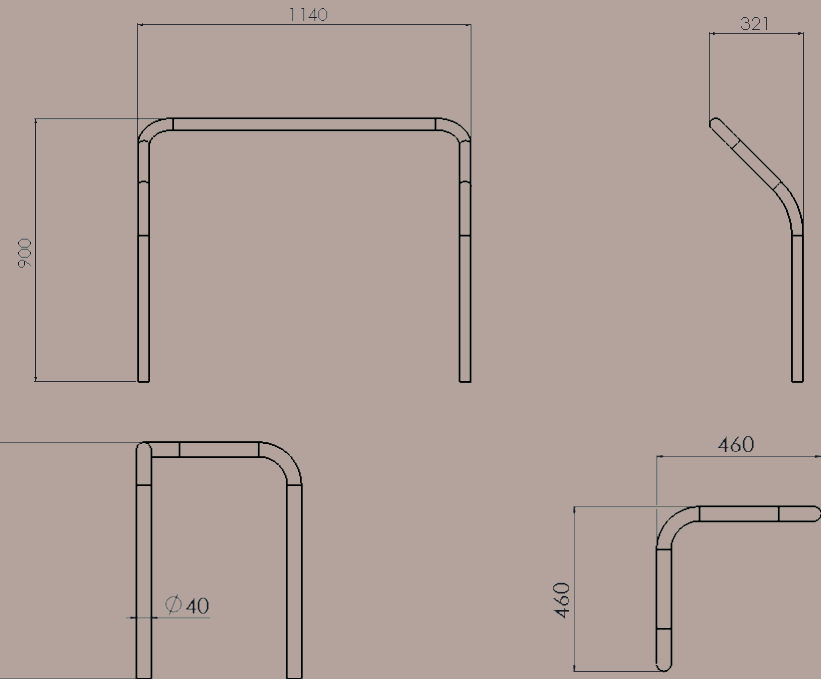

M/MOB1549A	374 €HT
-------------------	----------------

Bali bolt-on waste bin

- 12 slats made from treated and varnished exotic wood
- Steel structure – Kiln-finished green paint
- Capacity: 80 litres – Weight: 35kg
- Fitted with a removable bucket and base
- Cam lock and square key



PICNIC TABLE

Length: 200cm – Weight: 107kg

M/MOB1477V	291 €HT
-------------------	----------------

Length: 230cm – Weight: 117kg

M/MOB1478W	323 €HT
-------------------	----------------

Free-standing or bolt-on picnic table

- Made from autoclave-treated northern pine
- Class IV, FSC certified
- Anti-vandal (free-standing)
- Delivered with the surface and feet pre-mounted
- Fixing kit

Bolt-on kit

4 bolt panels + bolt kit

M/MOB1479X	23 €HT
-------------------	---------------

Installing your Euro-Relais point



Choosing the right location

The location must be flat and suitable for motor vehicles, with a minimum area of 10x10m. Allow for posts or walls, to house your signposting. Provide a 300kg concrete floor slab, with a minimum thickness of 100mm (especially if installing a shelter).

Before assembly

Before starting, it is essential that all of the inflow pipes have been carefully flushed.

Prepare your area:

- **Electricity**

Either 230V with a minimum of 9kW (for the Park, single-phase input 3x10mm²), directly from a connection box – Compliant with NF C 14100 (09/1996) – with an earth line using, for example, a peg connected to the shut-off strip on the point using bare 25mm² copper wire,

Or use a main LV panel in a private building (campsite) and an adapted multi-conductor cable, V/J conductor behaviour connected to the general earth line on the building side and the point shut-off strip. In this case, as the strip is insulated, if there is a specific earth line, then this line and the building earth line must be inter-connected.

A heating system is installed to prevent harmful condensation in places with high humidity and significant temperature variations.

- **Drinking water**

A plastic semi-rigid connection (Ø25/32) with valve and bleed tap, pressure reducer and filter provided (check valve recommended).

- **Drain**

Or collector for sump or pit according to current legislation. In any case, we recommend placing one or two inspection hatches with siphons. In the event that the slab is installed before the terminal is delivered, you will need 1, 2, 3 or 4 Ø100 90° toilet pipes.

**Find all of the information you need to install your
Euro-Relais points on our website:**

<http://www.bornes-eurorelais.fr/>



Descriptifs et normes des bornes Euro-Relais



Technical data sheet: Euro-Relais MINI

Weight: 90kg

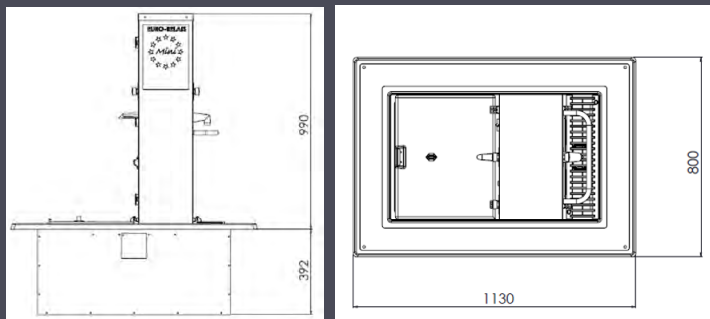

This unit includes:

A twin-lock door A twin-lock door

A plumbing part:

- Water supply through flexible tubing with a PRESTO tap (flow: 10L/min – duration: 30s)
- A grey and black water circuit in PVC tubing, with thermal insulation (optional)
- A PRESTO tap rinse system + 4 water nozzles for chemical toilet emptying (flow: 30L/min – duration: 6s)
- A PRESTO rinse tap for porta-potties (flow: 4L/min – duration: 15s) with integrated anti-blocking.

An electrical part

- A differential 40A – 30mA NF USE approved switch, compliant with NF EN 61008-1, NF C 15-100, recommended “comfort safety” label from promotelec.
- A 10A NF USE approved breaker, compliant with NF EN 60947-2, NF C 15-100, “comfort plus” label from promotelec.

Technical data sheet: Euro-Relais MAXI

Weight: 110kg 1v – Weight: 120kg 2v

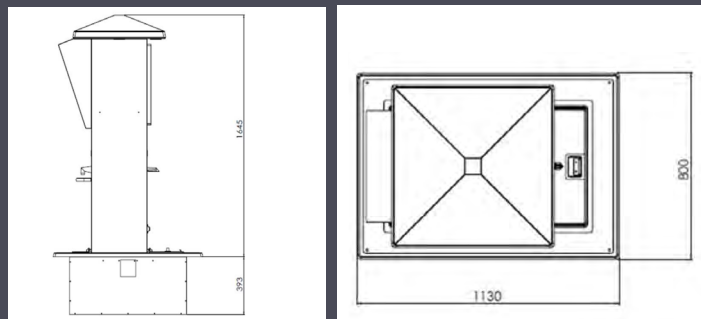

This unit includes:

A twin-lock door A triple-lock door

An electrical part

- A differential 40A – 30mA NF USE approved switch, compliant with NF EN 61008-1, NF C 15-100, recommended “comfort safety” label from promotelec.
- 2A, 10A and 16A NF USE approved breakers, compliant with NF EN 60947-2, NF C 15-100, “comfort +” label from promotelec.
- LED 0.8W/220V lighting

A plumbing part:

- Water supply through flexible tubing with a PRESTO tap (flow: 10L/min – duration: 30s), with thermal insulation
- A grey and black water circuit in PVC tubing, with thermal insulation. A convection heater is also installed to protect against condensation during temperature variations. (Optional for Maxi 1V)
- A rinse system + 4 water nozzles for chemical toilet emptying (flow: 30L/min – duration: 20s)
- A rinse tap for porta-potties (flow: 4L/min – duration: 20s) with integrated anti-blocking.

A payment part (choose 1):

- A terminal for payment by contactless card, QR code via smartphone, or by entering credit card numbers.
- A token payment system.

Technical data sheet: Euro-Relais PARK

Weight: 70kg

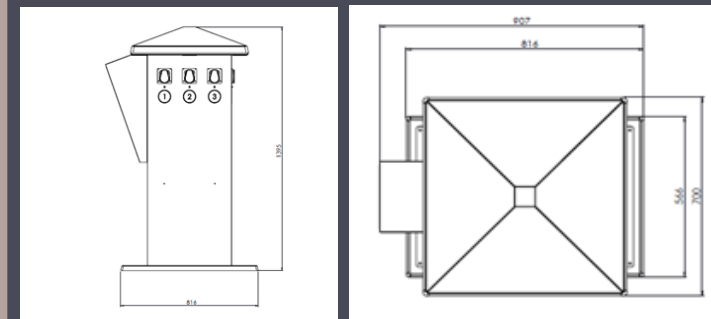

This unit includes:

A twin-lock door A twin-lock door

An electrical part

- A differential 40A – 30mA NF USE approved switch, compliant with NF EN 61008-1, NF C 15-100, recommended “comfort safety” label from promotelec.
- 2A, 10A and 16A NF USE approved breakers, compliant with NF EN 60947-2, NF C 15-100, “comfort plus” label from promotelec.
- Four differential 16A – 30mA breakers, NF USE approved and compliant with NF EN 60947-2
- Four water-proof P17 sockets
- LED 0.8W/220V lighting

A payment part:

- A terminal for payment by contactless card, QR code via smartphone, or by entering credit card numbers.

A sales team, right on hand



Our sales team will be pleased to guide you in your choices and help you meet your needs.



Xavier SCHIVRE

Tél. 07.88.97.53.37

xschivre@trigano.fr



www.bornes-eurorelais.com

3500 areas across Europe

Made in France



TRIGANO



A quick return on investment, for an economical and profitable solution

EURO-RELAIS
TRIGANO MDC
 ZA Le Haut-Éclair
 72600 MAMERS

Tél. 02 43 31 12 32
 Fax 02 43 31 12 31
 www.bornes-eurorelais.com
 contact@bornes-eurorelais.com



Cost of the CARD SERVICE POINT	8 945 €	Number of campervans required to pay for the SERVICE POINT (card payment)
Cost to refill 100 litres of water	3 €	2982
	4 €	2236
	5 €	1789

Cost of the EURO-PARK POINT	6 796 €	Number of campervans required to pay for the EURO PARK point (card payment)
3 hours' parking with electricity	4 €	1699
6 hours' parking with electricity	6 €	1132
12 hours' parking with electricity	10 €	679
24 hours' parking with electricity	15 €	453

Keeping close to your towns

Euro-Relais provides a genuinely turn-key solution to boost your tourism and promote the cultural heritage and value of your area. Euro-Relais' solutions are within the reach of any local authority. With Euro-Relais, it's our services which make all the difference! Grasp this opportunity and optimise the number of tourists coming through your commune! Local businesses will love you for it! With Euro-Relais, tourists will not hesitate to spend time in your area.

Protecting the environment

Environmental protection has become a top priority, so Euro-Relais creates spaces that are built to last. You're sure to love it – say goodbye to "wild" tourism! Thousands of campervans drive all over Europe every year, and Euro-Relais is here with the solutions and support you need! We offer excellent added value by providing equipment built for security, reliability and endurance.

With Euro-Relais, our premium services really make a difference! Euro-Relais utility points help protect the environment by collecting the grey and wastewater from campervans safely and legally.

Bringing in more tourists

Do you want to bring a new dimension to your local area? Euro-Relais is here to help make your service and stopover area project a success, helping you bring more tourists every year. Take a new look at the services that can make or break your local area's reputation. Place modern and ultra-convenient commodities in your tourist spaces and make the most of your position as a strategic cross-road! With Euro-Relais, we'll give you a truly global solution!